

Adaptive Carrier Suppression for UHF RFID using Digitally Tunable Capacitors

Marcel Koller

Zurich University of Applied Sciences
ZSN Center for Signal Processing and Communications
CH-8401 Winterthur, Switzerland

Roland Küng

Zurich University of Applied Sciences
ZSN Center for Signal Processing and Communications
CH-8401 Winterthur, Switzerland

Abstract—In UHF (Ultra High Frequency) RFID (Radio Frequency Identification) systems Rx (Receiver) is usually isolated from Tx (Transmitter) by a circulator or a directional coupler. Since tags become more sensitive in order to improve reading distance, the relatively poor isolation of 20dB – 30dB limits the tag to reader link. A way to improve a directional coupler's isolation is to mismatch the unused port to generate a carrier cancelling signal. In this paper an impedance network using digitally tunable capacitors is proposed. The advantage of this solution is that changes in the system – like antenna characteristics or cable length - can be recalibrated at any time by a controller. Finally an isolation of minimum 47dB for any antenna characteristic (minimum return loss of 18dB) and any cable length was reached. Also an algorithm was implemented on a simple MSP430 controller to find the optimum impedance to minimize carrier leakage.

Keywords—RFID; UHF; directional coupler; circulator; leakage canceling; isolation; carrier suppression

I. INTRODUCTION

Passive UHF RFID tags become more and more sensitive in order to increase reading distance. Even higher sensitivities are realized with semi-active tags. While the carrier power of the reader is limited by regulations, reducing the power consumption of the tags is the main potential to improve the reader to tag link. On the other hand this also increases the requirements of the tag to reader link. The backscatter technique used in RFID requires a continuous carrier from the interrogator to deliver power to the transponder. Its response is modulated onto the carrier. The reader has then to separate the weak answer signal from the strong carrier and its noise. This is done by coupling elements like circulator or directional coupler. However these elements cannot perfectly isolate Rx from Tx. There are three possible ways for the carrier to leak into the receiver part of the reader as shown in Figure 1. While the isolation of the coupling element and the reflection at the antenna are fixed parameter for one specific setup, reflections at environmental objects are time variant.

There are two main issues caused by the carrier leakage. First a high power signal can saturate the mixer in the receiver part and limits its performance. The receiver part of the AS3992 [7] requires the carrier to be suppressed below -5dBm to show its full performance. Assuming transmit power at 27dBm carrier suppression of at least 32dB is necessary. Another issue is the phase or amplitude noise of the carrier

limiting the SNR (Signal to Noise Ratio) at receiver part. For the tag signal detection in EPC Gen2 systems typically the relevant noise part is situated at an offset of 250kHz and covers a bandwidth of 100kHz. To make full use of the reader chip sensitivity of -80dBm [7], the carrier noise density must be suppressed below -130dBm/Hz. A quick calculation with a typical phase noise of an integrated RFID reader transmitter design as published in [5] gives a noise density of 120dBc/Hz. For the assumed transmit power of 27dBm this corresponds to -93dBm/Hz. Therefore at least 37dB carrier suppression is needed to use the maximum chip sensitivity.

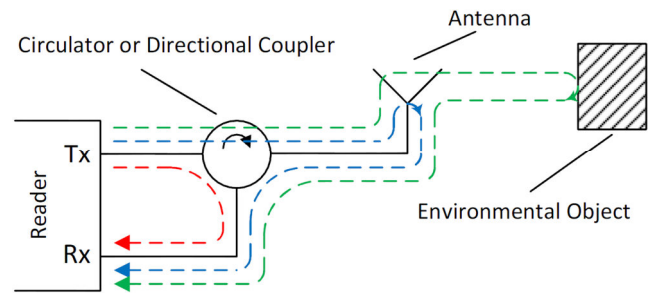

Fig. 1. Tx to Rx carrier leakage paths

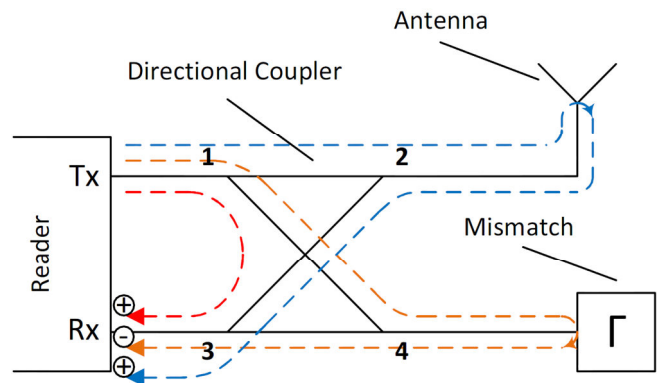

Fig. 2. Principle of the mismatched coupler

Static solutions to improve the isolation using a directional coupler mismatched at the unused port have been proposed in [1], [2] and [3]. In common applications the unused port 4 of a directional coupler is terminated with 50Ω so that there are no reflections. To reduce carrier power at port 3, power can be reflected at port 4 in a way that the power reflected at the antenna and the power leaking from port 1 to port 3 is cancelled out as shown in Figure 2. Cancellation solutions with static impedances (lumped elements or transmission lines) do not take account of environmental reflections. Another disadvantage is that the impedance has to be calibrated for each antenna impedance and cable length.

The proposed carrier suppression method in this paper shows its full benefit because it cancels out not only the carrier power but also the intrinsic amplitude and phase noise. As the phase noise is correlated to the receivers local oscillator noise the cancellation will be almost perfect. Even uncorrelated phase noise generated by the power amplifier can be cancelled out with the proposed method. This is a great advantage compared to all methods using vector modulator [9] or I/Q-modulator [5] to cancel the carrier with active means. These modulators contribute their own uncorrelated noise to the receiver which cannot be cancelled out afterwards. Similar, methods with PIN-diodes [4] contribute uncorrelated noise caused by the bias current. Instead, only RLC elements are used. The two capacitor devices are tunable and show very high linearity (Third order input intercept point of 65dBm [6]).

II. THEORY OF THE MISMATCHED COUPLER

In a static system where the reflection coefficient of the antenna Γ_{Ant} and the S-parameter of the directional coupler S_{ii} are known, the optimum reflection coefficient at port 4 Γ_4 can be derived. The power P_3 leaked into Rx is calculated in eq. (1), where P_1 is the transmit power of the reader.

$$P_3 = P_1(S_{31} + S_{21}\Gamma_{Ant}S_{32} + S_{41}\Gamma_4S_{34}) \quad (1)$$

To derive Γ_4 , P_3 is set to zero and the equation is solved to Γ_4 as shown in eq. (2).

$$\Gamma_4 = -\frac{S_{31} + S_{21}\Gamma_{Ant}S_{32}}{S_{41}S_{34}} \quad (2)$$

Two special cases can be mentioned. For a perfect matched antenna ($\Gamma_{Ant} = 0$) eq. (2) becomes

$$\Gamma_4 = -\frac{S_{31}}{S_{41}S_{34}} \quad (3)$$

In this case only the directional coupler itself is improved. For a perfect coupler ($S_{31} = 0, S_{21} = S_{34} = 1, S_{41} = S_{32}$) eq. (2) becomes simply

$$\Gamma_4 = -\Gamma_{Ant} \quad (4)$$

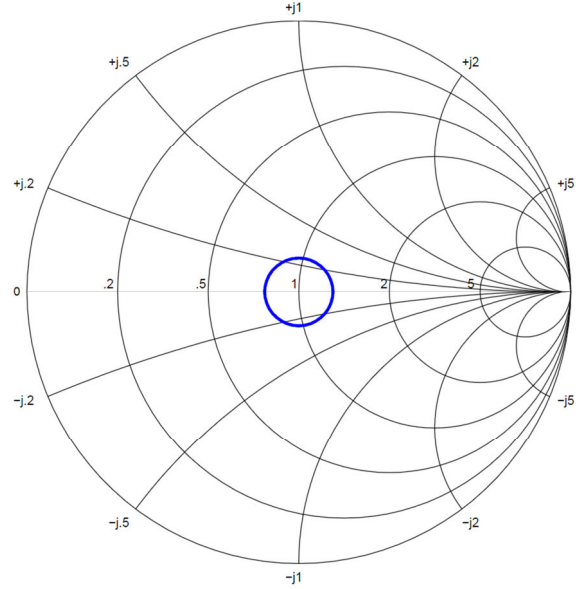

Fig. 3. Impedance area for 18dB antenna reflection loss

III. SIMULATION

Standard UHF patch antennas usually have a minimum return loss of about 18dB, which corresponds to a reflection coefficient magnitude of 0.125. Neglecting the non-ideal S-parameter of the directional coupler the optimum impedance at port 4 will also lie within the 0.125-circle as shown in eq. (4). This is illustrated in the smith chart in Figure 3.

Therefore a tunable impedance has to cover this area. The impedance network has to include at least two tunable elements in order to adjust real and imaginary part of the impedance. Figure 4 shows one possible network using two digitally tunable capacitors PE64904 from Peregrine Semiconductor [6]. The capacitors have a range of 0.6pF – 4.6pF in series and 1.14pF – 5.1pF in shunt configuration with a resolution of 129fF. This equals to 32 steps. The two ranges are modified with the parallel capacitor C_1 and inductor L_2 respectively. R and L_1 are needed to reach the area of interest (around the 50Ω -point) in the smith chart. Figure 5 shows the impedance area covered by this network. Totally 331 points are lying within the circle of 18dB return loss, which allows a very accurate adjustment of the impedance. Figure 6 shows the attenuation between Tx and Rx in dB for all 1024 (32x32) possible combinations of capacitor values.

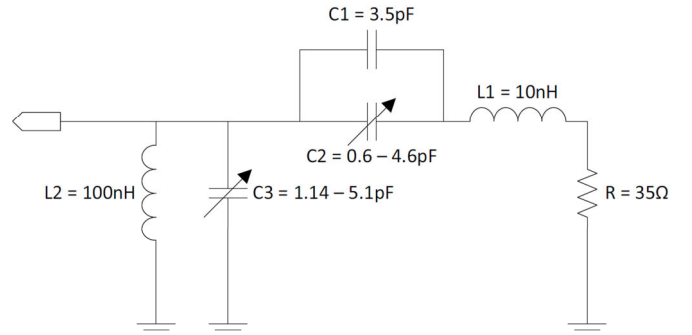

Fig. 4. Simulated impedance network

For this case the following directional coupler S-parameter and antenna reflection coefficient were used:

- $S_{31} = 0.0001$
- $S_{21} = -0.335 - j0.883$
- $S_{32} = 0.288 - j0.101$
- $S_{41} = 0.288 - j0.102$
- $S_{34} = -0.295 - j0.897$
- $\Gamma_{Ant} = 0.029 - j0.095$ (RL = 20dB)

The highest attenuation can be reached with the values $C_2 = 2.019pF$ and $C_3 = 2.922pF$. Figure 7 shows another example with $\Gamma_{Ant} = -0.176$ (return loss = 15dB). This example shows the limit of the network. The optimum impedance lies not within the covered area. Nevertheless there is still a benefit compared to a simple 50Ω termination when $C_2 = 4.6pF$, which is the maximum, and $C_3 = 2.41pF$.

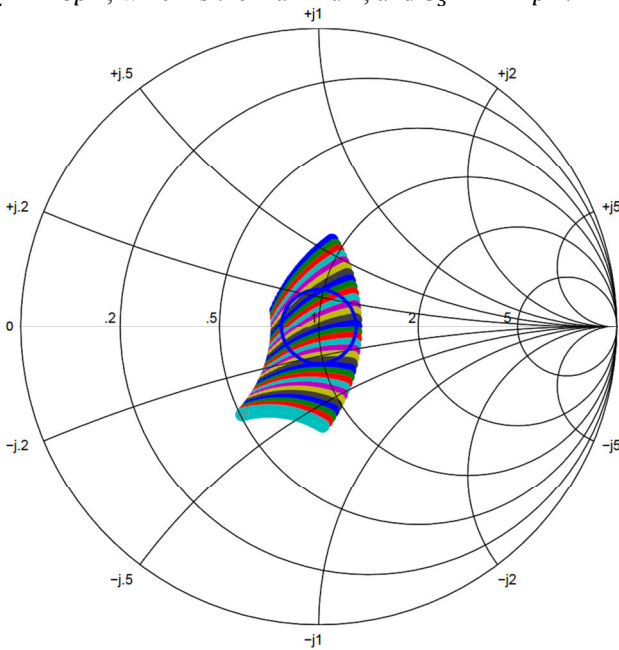

Fig. 5. Simulated impedance area

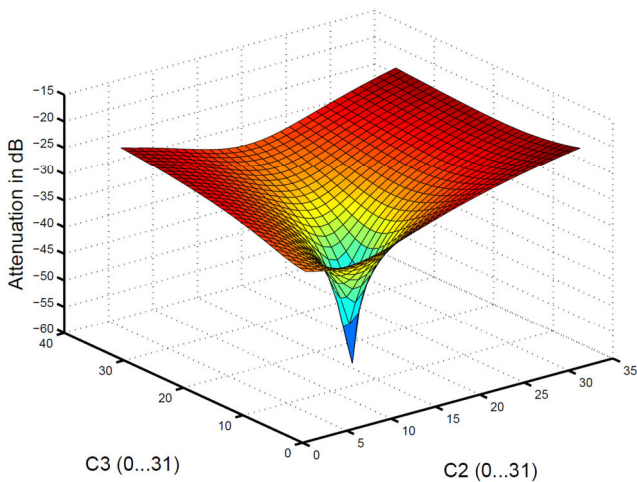

Fig. 6. Tx to Rx carrier attenuation with RL=20dB

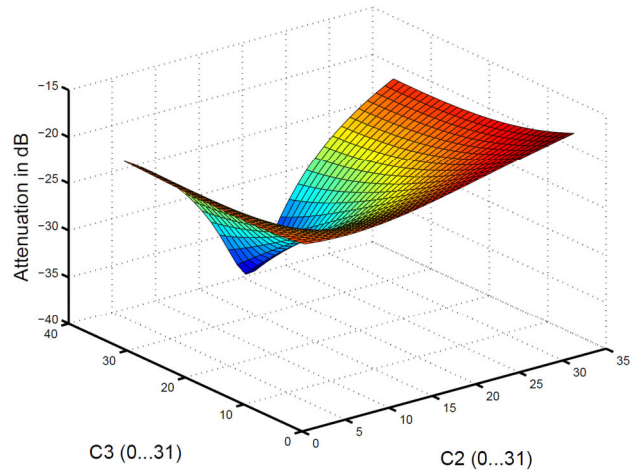

Fig. 7. Tx to Rx carrier attenuation with RL=15dB

As Figure 6 and Figure 7 show there is always only one minimum existing and the function is continuous. Therefore it is relatively easy to find the minimum by following the gradient starting at two random capacitor values. Once the minimum is found, the algorithm will readjust the impedance automatically if the carrier leakage changes.

IV. IMPLEMENTATION

The simulated impedance network has been implemented on FR4 material. Figure 8 shows the network with updated values due to parasitic effects of the tunable capacitors. Figure 9 shows the layout with a 50Ω-line to a SMA-connector. SPI (Serial Peripheral Interface) and power pins are easy to connect and not shown in detail.

The algorithm to follow the gradient of the carrier leakage is implemented on a simple MSP430 microcontroller. Usually in a reader unit there is a host controller, which can be used for that. The capacitors are programmed over SPI. The carrier power at the Rx path is measured with a RF detector, for example LT5534.

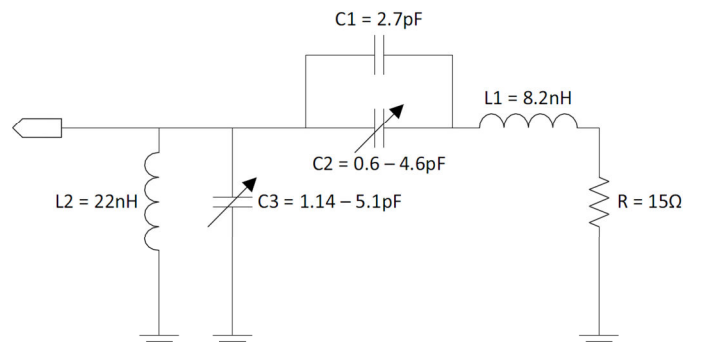

Fig. 8. Implemented impedance network

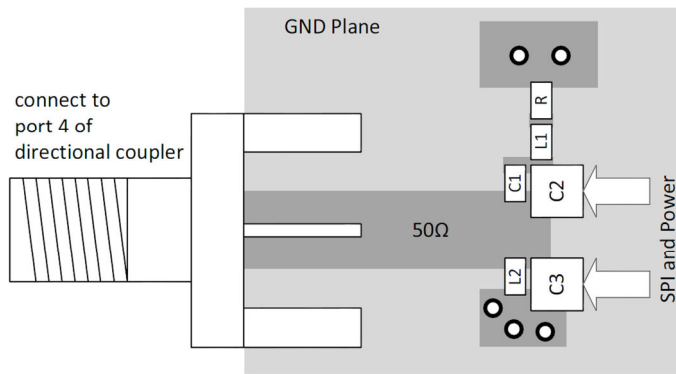

Fig. 9. PCB Layout

V. MEASUREMENT

Figure 10 shows the complete measurement setup. An AMS RFID Reader [7] with output power of 27dBm is used to generate the carrier (Tx). The leaked signal is measured with a spectrum analyzer (Rx). Instead of a UHF patch antenna, loads with return losses of 18dB and 20dB are used to verify the method for different antenna performances. Different antenna cable lengths highly affect the carrier signal at the receiver. This is simulated with a phase shifter. Table 1 shows the measured carrier power at Rx for the 50Ω termination, which must be below -5dBm. Since the load is not exactly 50Ω, there is always a best and a worst case for the cable length. Table 2 shows the measured carrier power at Rx for the tuned impedance. The measurement shows that the proposed method suppresses the carrier to 20dBm or less for antennas with a minimum return loss of 18dB. The carrier suppression can be calculated as the difference between the transmit power of 27dBm and the received power. Since the impedance is always recalibrated, the cable length doesn't play the same role as for the 50Ω termination as long as the antenna impedance lies within the area covered by the network.

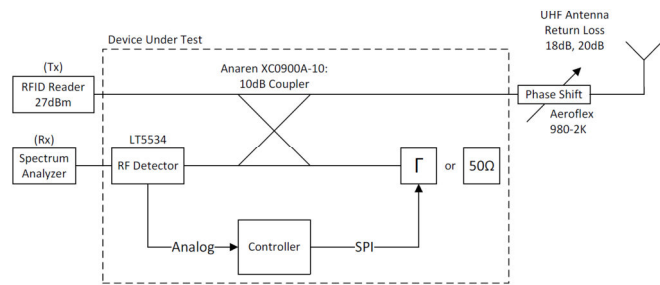

Fig. 10. Measurement setup

Table 1. Received carrier power with 50Ω termination

Return Loss	Cable Length	
	Best Case	Worst Case
18dB	-12dBm	0dBm
20dB	-18dBm	-2dBm

Table 2. Received carrier power with tuned impedance

Return Loss	Set of values for 4 different cable lengths
18dB	-43dBm, -20dBm, -24dBm, -33dBm
20dB	-28dBm, -20dBm, -23dBm, -31dBm

VI. CONCLUSION

A novel method for carrier suppression is proposed using a RLC-network with digitally tunable capacitors on port 4 of a directional coupler. This method also cancels out the carrier intrinsic noise without adding uncorrelated noise. The cheap and easy to implement solution isolates the carrier by a minimum of 47dB. This is 10dB more than needed for today's reader chip designs and gives room to improve reading distance by a factor of 3.

REFERENCES

- [1] Wan-Kyu Kim, Won Na, Jong-Won Yu, Moon-Que Lee, "A high isolated coupled-line passive circulator for UHF RFID reader," *Microwave and Optical Technology Letters*, Vol. 50, No. 10, pp. 2597-2600, October 2008
- [2] Feng Wei, X. W. Shi, Q. L. Huang, D. Z. Chen, X. H. Wang, "A new directional coupler for UHF RFID reader," *Microwave and Optical Technology Letters*, Vol. 50, No. 7, pp. 1973-1975, July 2008
- [3] Wan-Kyu Kim, Moon-Que Lee, Jin-Hyun Kim, Hyung-Sun Lim, Jong-Won Yu, Byung-Jun Jang, Jun-Seok Park, "A passive circulator with high isolation using a directional coupler for RFID," *Microwave Symposium Digests, 2006. IEEE MTT-S International*, pp. 1177-1180, June 2006
- [4] Thomas Brauner, Xiongwen Zhao, "A novel carrier suppression method for RFID," *Microwave and Wireless Components Letters, IEEE*, Vol. 19, pp. 128-130, March 2009
- [5] Pekka Pursula, Mikko Kiviranta, Heikki Seppä, "UHF RFID Reader with Reflected Power Canceller," *Microwave and Wireless Components Letters, IEEE*, Vol. 19, pp. 48-50, January 2009
- [6] Peregrine Semiconductor, "PE64904 Datasheet,"
- [7] Austria Micro Systems, "AS3992 Datasheet,"
- [8] Min-Suk Kim, Seonghan Ryu, Sung-Chan Jung, Junhee Oh, Youngoo Yang, "Low Phase Noise CMOS VCO for UHF RFID Reader System," *Microwave Conference Proceedings (APMC), 2011 Asia-Pacific*, pp. 777-780, December 2011
- [9] Iker Mayordomo, Josef Bernhard, "Implementation of an adaptive Leakage Cancellation Control for passive UHF RFID Readers," *IEEE International Conference on RFID*, pp. 121-127, April 2011